



Winlink 2000

Digital Messaging for ARES®

“Our primary mission is to provide Global digital communications for the benefit, safety and well-being of the user community, anywhere, anytime, anyplace.”

By

Steve Waterman, K4CJX

(help from Loring Kutchins, W3QA)

Winlink 2000 Network Administrator,

Winlink 2000 Development Team

LORING A KUTCHINS

revised January 20, 2005





In addition to our individual ARES® users,
we stand by our Commitment to our
community Government and Civil Agencies :





- **To Supply De facto e-mail:**

- using their *existing* e-mail programs,
- on their *own* computers in their *own* offices,
- with *no* additional invasive software,
- seamlessly, transparently, from user-to-user.
- from inside their own County or around the world
- from *inside* a disaster area, and *without* normal e-mail servers or Internet links.

This is the purpose of *Winlink 2000* E-mail via Amateur Radio



Agency Focus on Emergency digital communications

Normal E-mail requires an internet connection

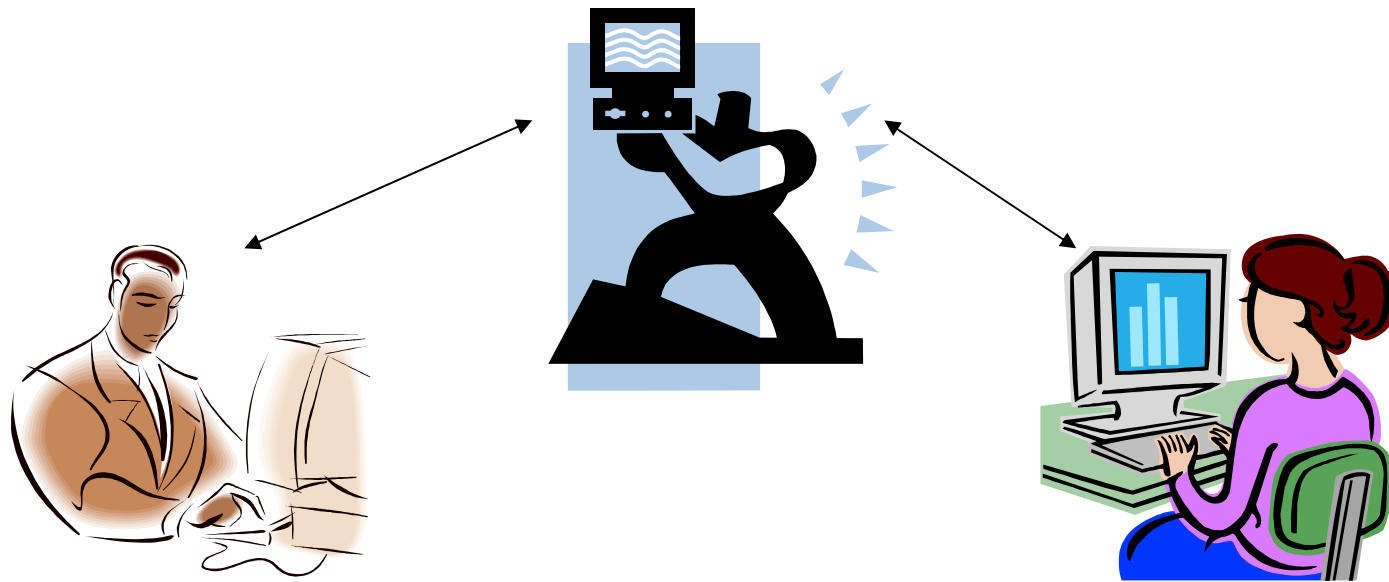

Critical

- Between Agencies
- Between an Agency and the Field
- Between an Agency to multi-points
- Between Agencies and *anywhere!*

Routine

Agency Focus

- If a community “**Last Mile**” internet link is broken, or the agency e-mail server is down, e-mail ***cannot*** flow.

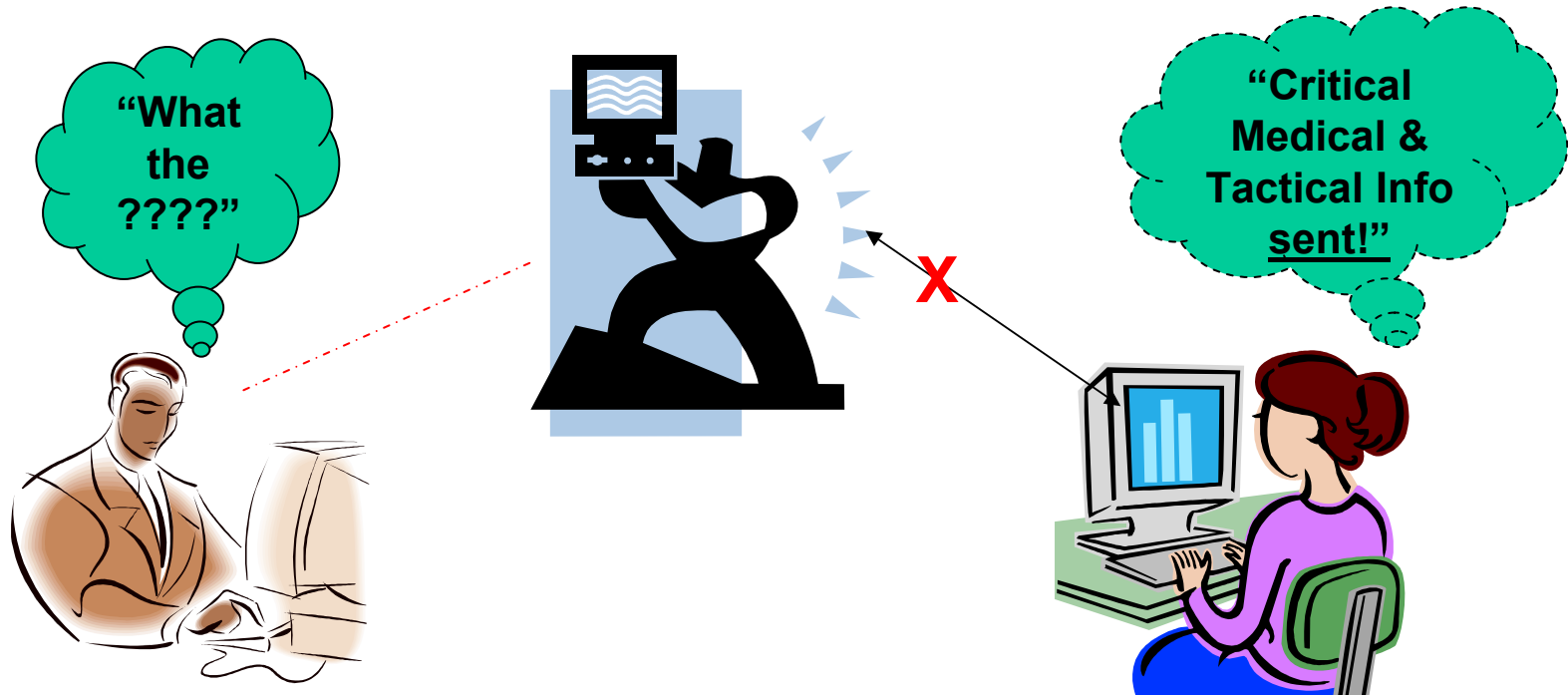

The “*last mile*” is an important concept in Emergency Communications.

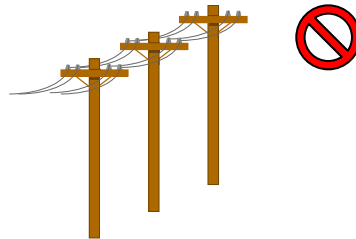

The “last mile” is the path across an area where conventional communications have been ***disrupted or overloaded*** by an incident.

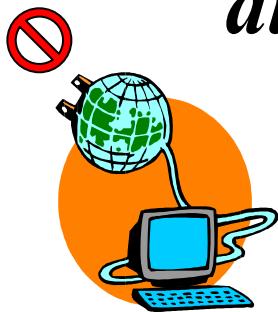

Unfortunately, in today's World, we cannot predict the frequency, size, nature or location of our disaster areas! We be must prepared, Globally.

Local?



Regional?



Global?



Winlink 2000 is primarily a *donated*, dependable, transparent, back-up E-mail system that bridges *any* distance.

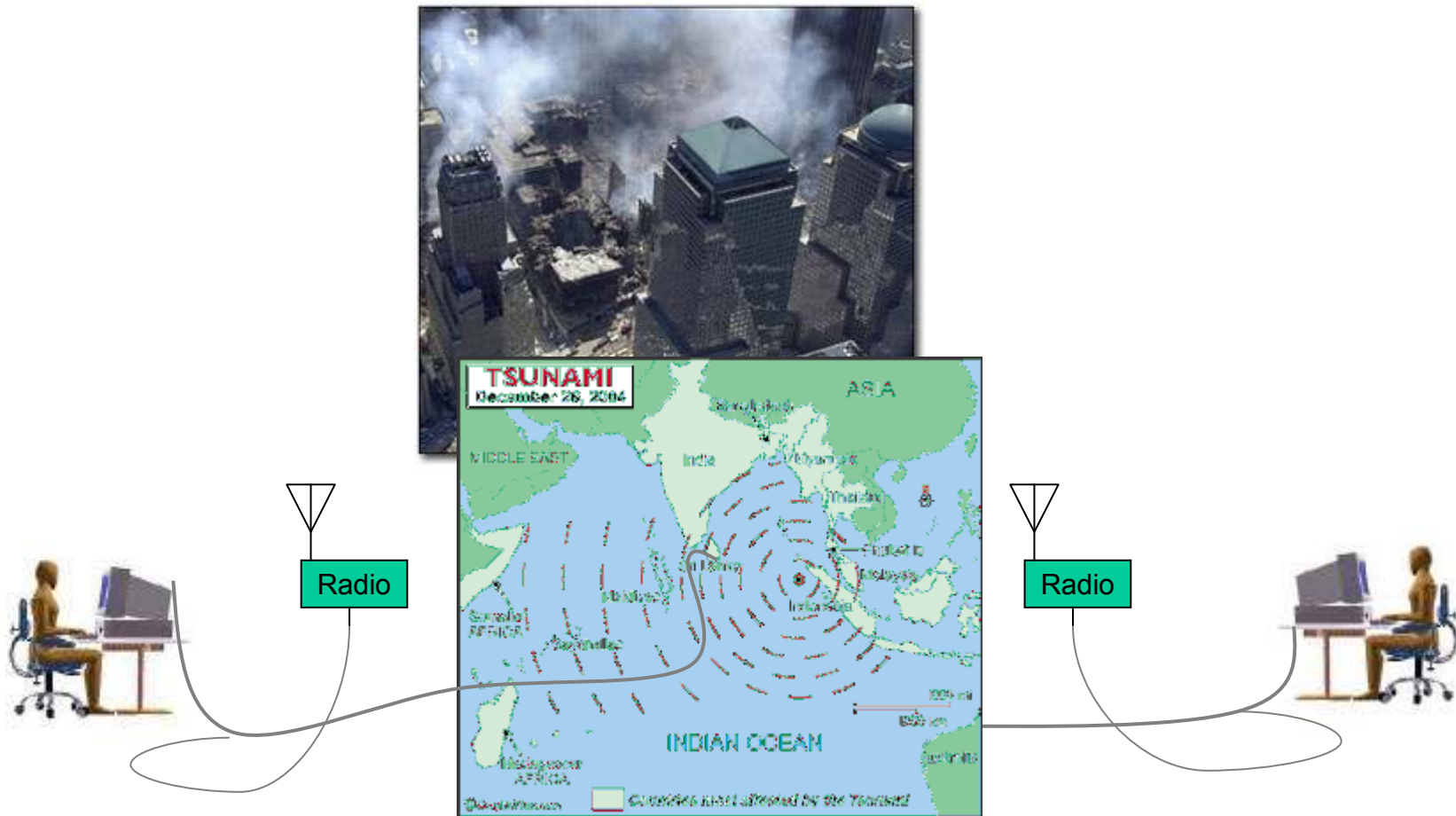

For the end user it must:

- look like *e-mail and use familiar software like Outlook*
- have an *address book* and a *spell-checker*
- allow *multiple recipients (to:, cc:)*
- send *multiple attachments*
- be able to use *tactical email addresses*
- and ***NOT add to the stress*** or learning curve when in an emergency situation

System Requirements:

- It must work on *multiple computers* on a LAN without additional desktop software, and *not invade security*,
- be *automated*,
- use available and future digital radio modes,
- interface with *commercial communications systems* like telephone, cellular telephone, the Internet, etc.,
- have *speed, performance* and *accuracy*,
- and *immediately* deliver emergency traffic seamlessly, *end-to-end*.

Why?

Moving into the 21st Century

Accuracy

Consistency

Record tracking

“Written documents impose their own kind of discipline”

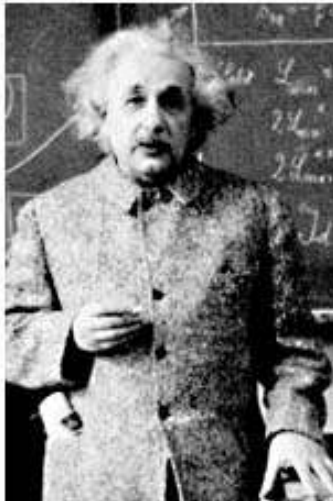

Albert Einstein

“I can't work without a blackboard!”

Why? Traditional role of Amateur Radio support:

- Report *health and welfare* of affected public
- *Voice communications* among served agencies (EOC's, hospitals, shelters, and incident command.)
- Site *tactical support* – Incident Command, search and rescue, damage and storm reporting (SKYWARN).
- “Formal,” Structured *written emergency traffic* handling.

Why? Our traditional methods *fail* for complex message handling in today's agency environment!

- Since the advent of e-mail:
 - Need for delivering written procedures, lists, graphics, images, and Pre-defined, formatted, documents to multiple recipients!
 - Multiple recipient *e-mail* with *binary attachments* is the de facto standard to carry written information.
 - Hand-written message forms are seldom used, and are *not transparent* to normal operations!
- For complex messages, voice, Morse code, Radiograms, and traditional Packet radio *won't* do...
 - way too slow, translation required, inflexible, prone to error, no permanent record, not self-originating, not point-to-multipoint.
 - doesn't go end-to-end from user-to-user on their *own* computers in their *own* offices & no attachments and no automatic distribution..

Emergency Digital (written) Complex Communications For Community Agencies

With Telex? When was the last time an agency used Telex?

With a Telegram? When was the last time they sent a Telegram?

With a voice relayed NTS Radiogram or MarsGram? (could be an attachment)

With WORLI Packet “H-routing”? “HUH???” “Do what???”

The accepted Global standard is now SMTP e-mail !



We can keep Agencies connected
without an immediate Internet
connection.



Bottom Line: Let's make EmComm as easy & transparent as possible for those who need it during an emergency situation.

Let's not forget: It is their “party” and we want to be invited!

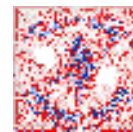

Why? The ARRL is now *implementing* a National Plan

July, 2003: In cooperation with its partnership with Homeland Security, and at their recommendation, the ARRL Board has agreed to provide a *nationwide digital system to enhance the communications capability of the Amateur Radio Emergency Service (ARES®)*.

There are situations, the Board said, when ARES® "must have the capability to pass digital traffic across the nation quickly and accurately."

It must also be transparent, seamless, end-to-end, and take only minutes from origination to destination.

E-MAIL VIA HAM RADIO



How ?

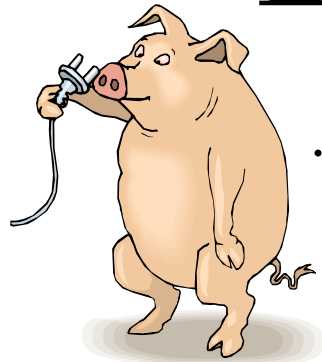

...do Hams do that?

E-MAIL VIA HAM RADIO using Winlink 2000

A typical ham radio “last mile” e-mail station is composed of simple components, even for an Agency with multiple computers.

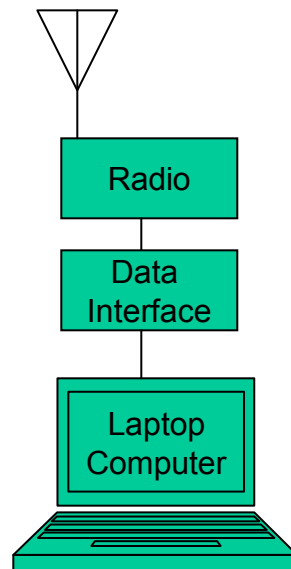
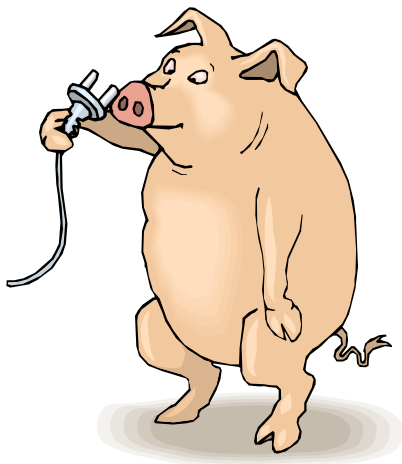

**This is a Winlink 2000
PACLINK station.**

A VHF or UHF [Radio](#) and a [Good Antenna](#)

A D-Star or Packet Radio [Modem](#) (TNC.)

[Laptop](#) for a Portable Station.
[Desktop](#) for an agency.

- [Paclink AGW & Paclink Postoffice](#) mini e-mail server software with
- [AGW Packet Engine Pro](#) and
- [Outlook Express](#) or [Outlook](#)
- [Win2000](#) or [WinXP](#)

E-MAIL VIA HAM RADIO

To send or receive e-mail, this station makes a connection with a Winlink radio node or **PMBO**.

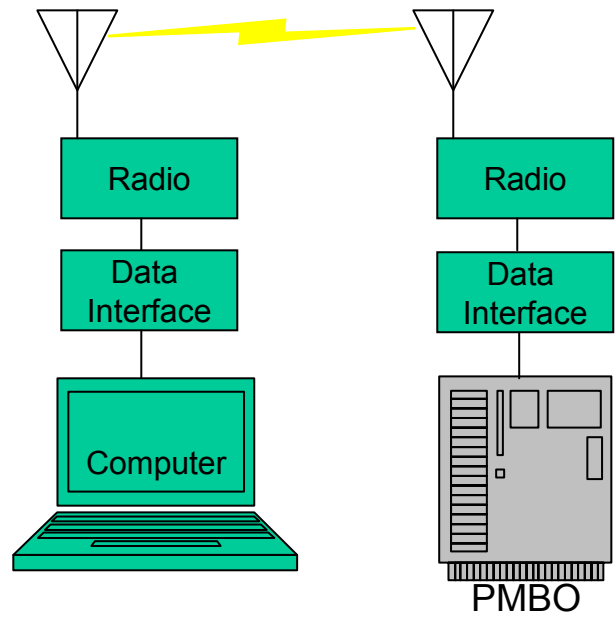
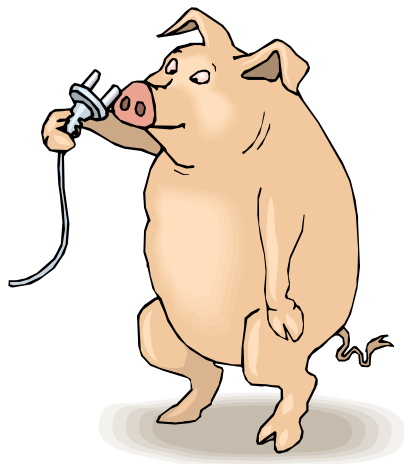

E-MAIL VIA HAM RADIO

For the “last mile,” use **VHF** radios and the **Packet** mode as a *pathway* to carry e-mail.

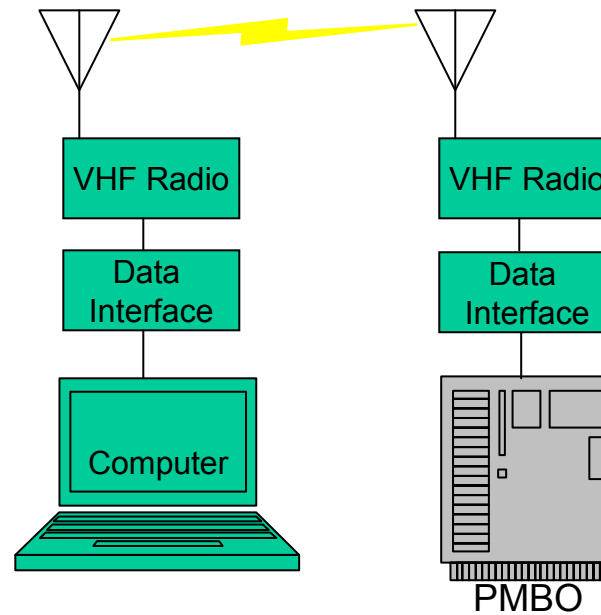
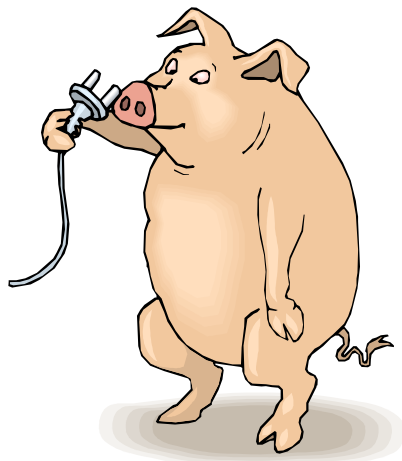

E-MAIL VIA HAM RADIO

For longer distances or in difficult terrain, most PMBOs are outfitted with multi-band HF radios and the Pactor II & III modes to serve stations with no other e-mail outlet.

Users on HF have a special e-mail program called "Airmail."

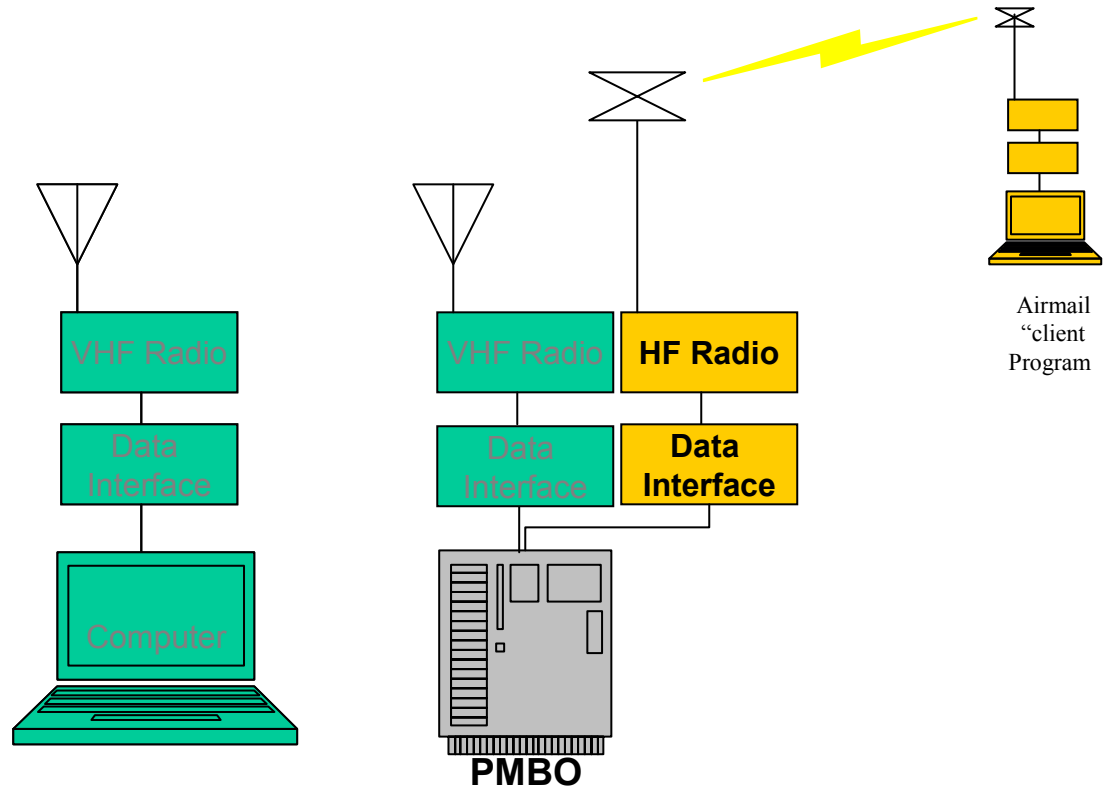
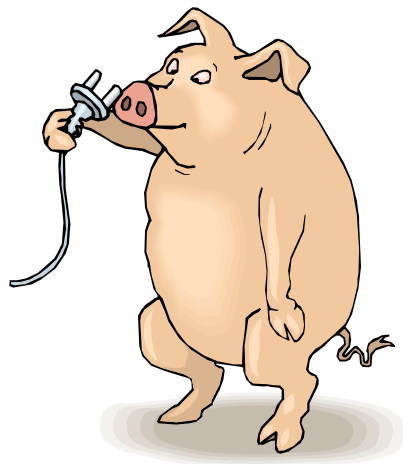

E-MAIL VIA HAM RADIO

The **PMBO** is connected to the internet **at all times**.

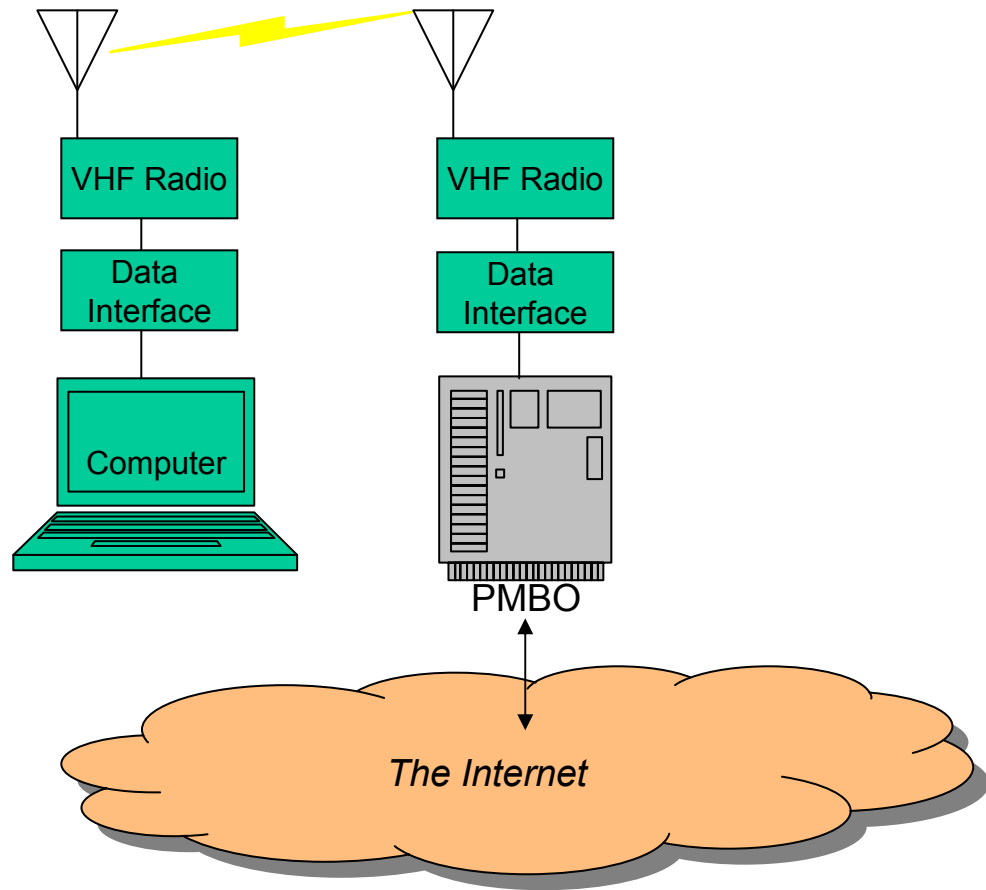
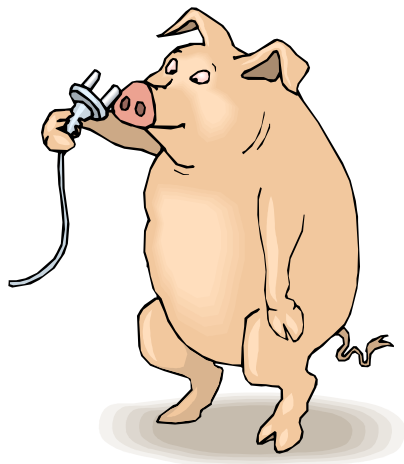

E-MAIL VIA HAM RADIO

PMBOs may have remote “gateways” called TELPAC stations. They are connected to the PMBO via any TCP/IP link and duplicate its VHF radio port in another location.

TELPAC stations may communicate to the PMBO via any TCP/IP link, including ICOM’s D-Star or “WiFi” 802-11b.

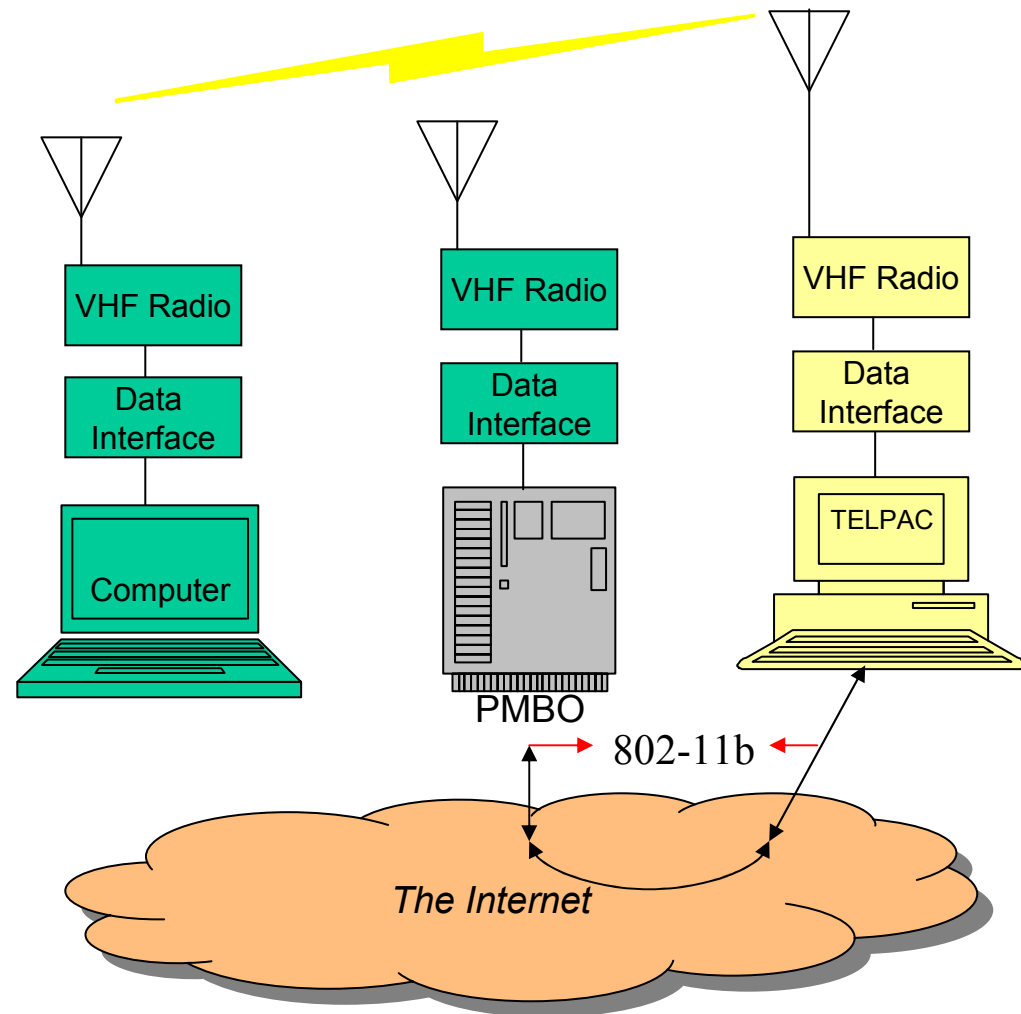
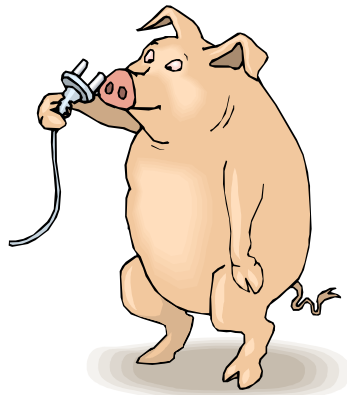

E-MAIL VIA HAM RADIO

Other computers, or **CMBOs**, organize and manage the network traffic.

CMBOs are transparent to users. They are redundant, and you never know they are there.

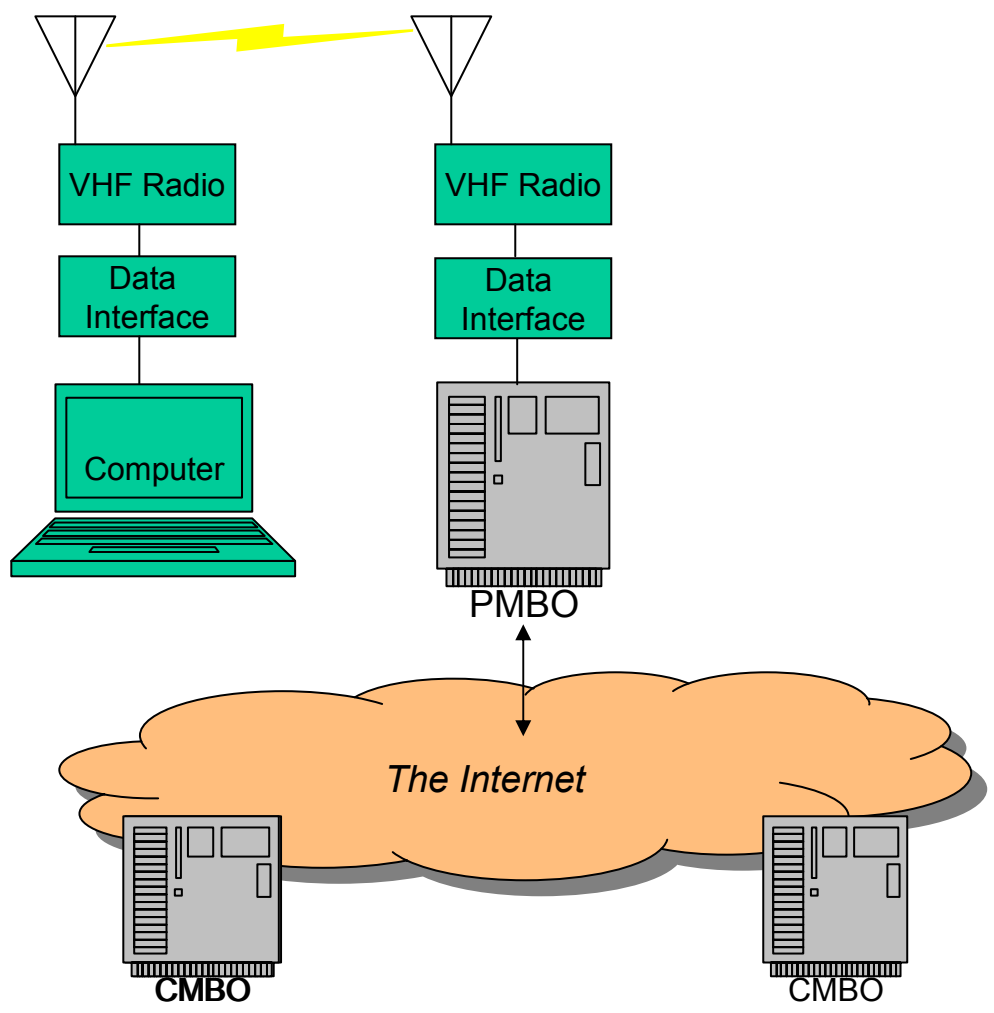
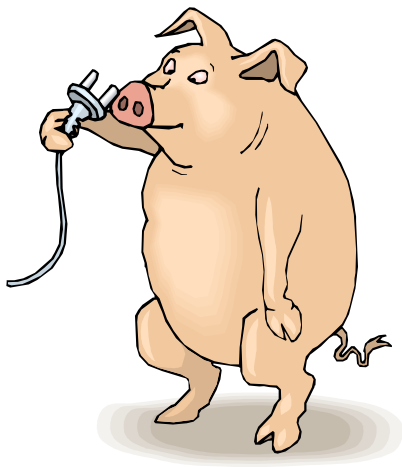

E-MAIL VIA HAM RADIO

You can send radio e-mail directly to internet e-mail users.

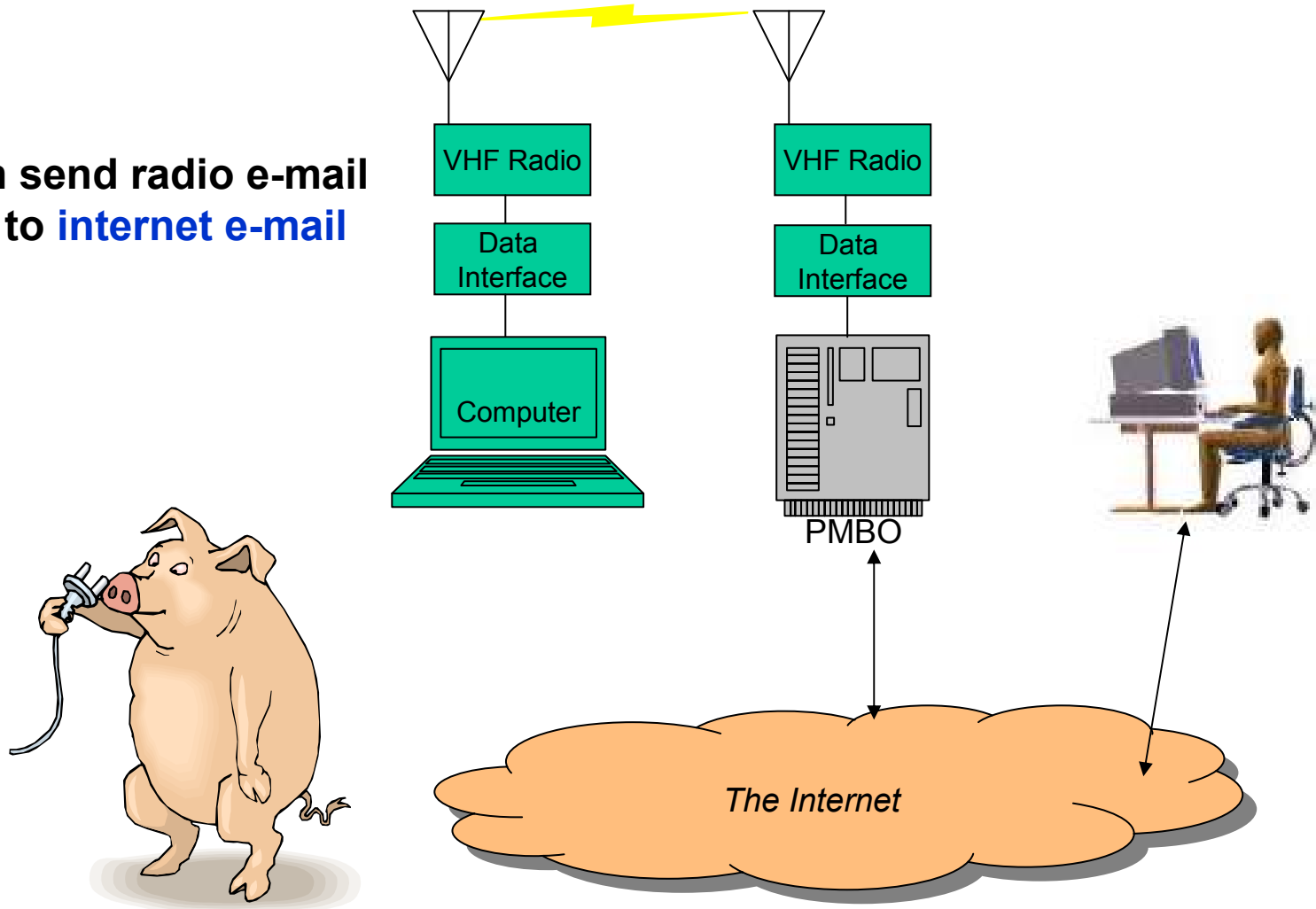

E-MAIL VIA HAM RADIO

And you can send radio e-mail to other **Paclink** or **Airmail** stations like yours.

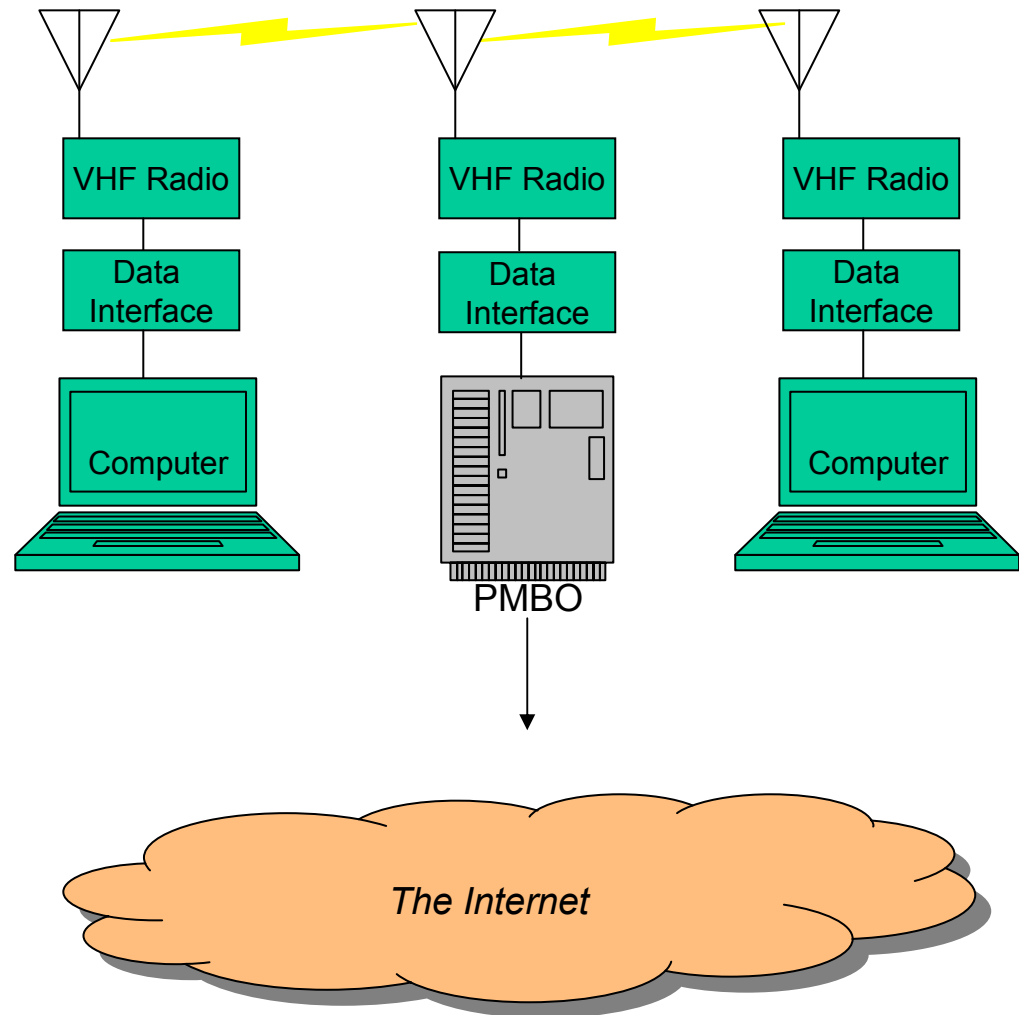
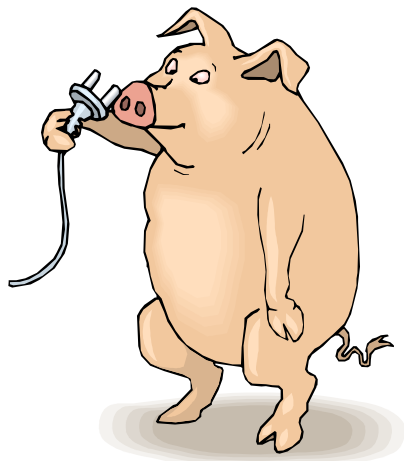

E-MAIL VIA HAM RADIO

Adding a LAN on the **PACLINK** computer permits individuals to send and receive radio e-mail. **PACLINK** is now an e-mail **server**.

PACLINK may be placed in the “DMZ” zone in front of the firewall.

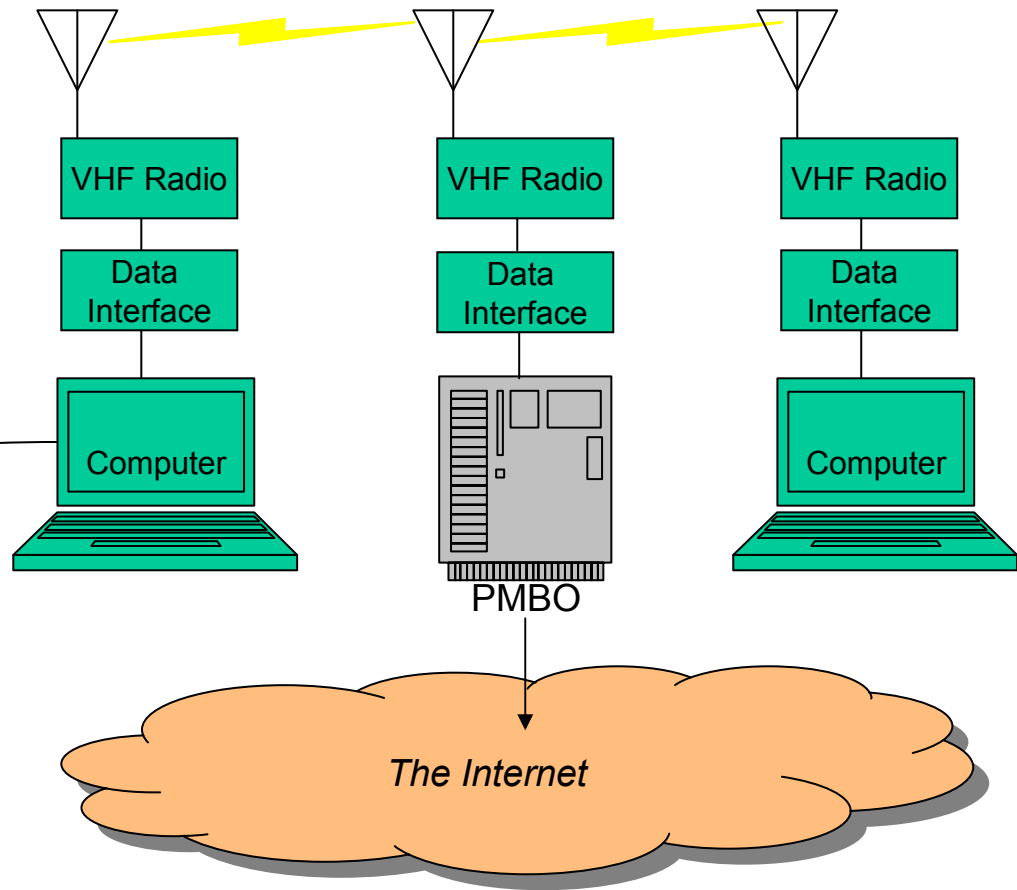
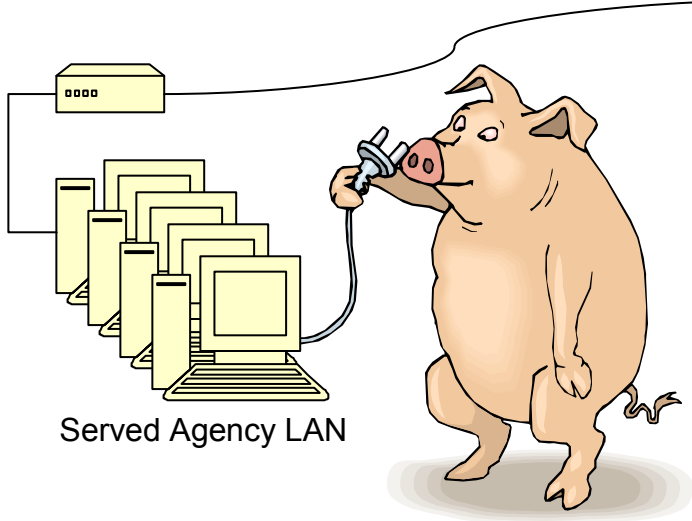

E-MAIL VIA HAM RADIO

The **PMBO** forwards radio e-mail between its radio users, **even if its internet connection is gone.**

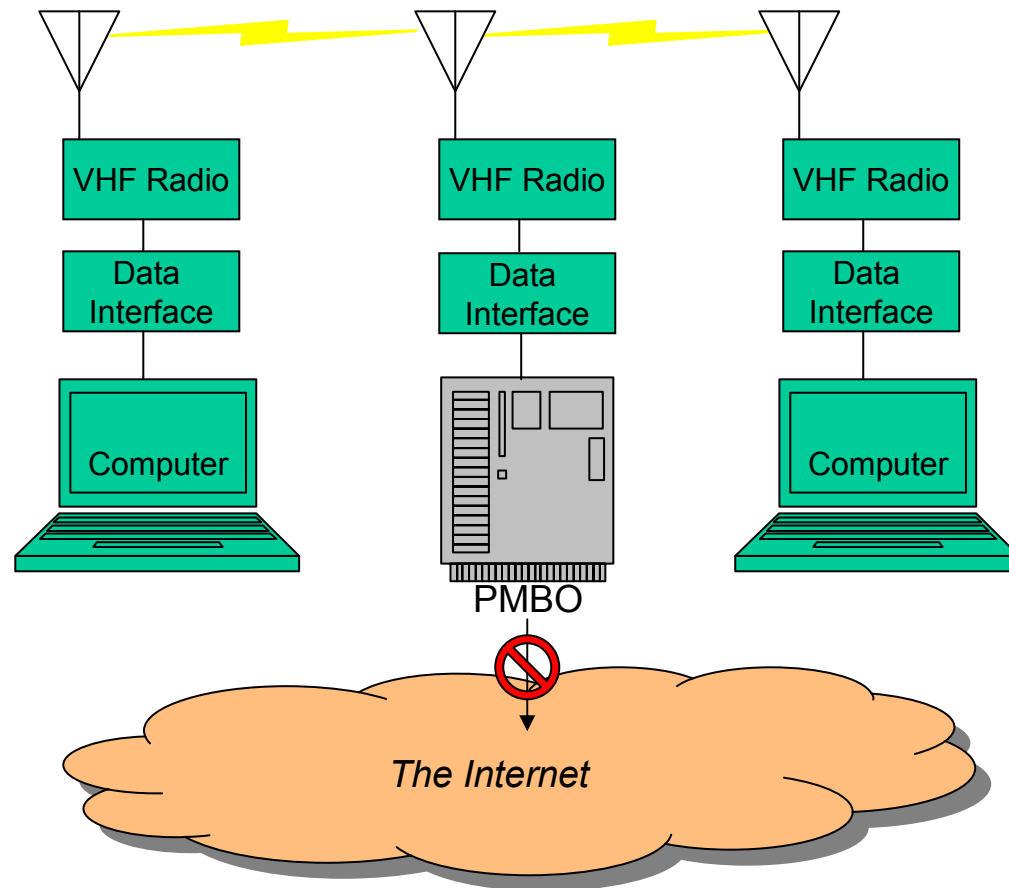
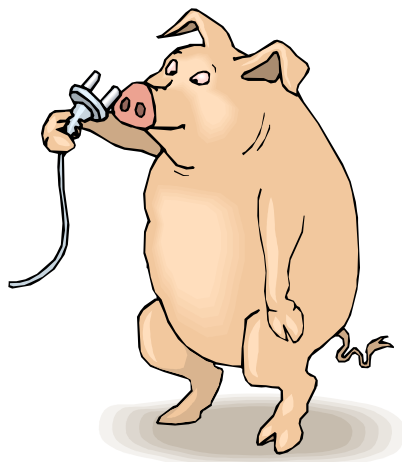

E-MAIL VIA HAM RADIO

If the local **PMBO** has an outage, you can make a connection with a local **TELPAC** station which will automatically shift to a distant host **PMBO** with connectivity. Or...

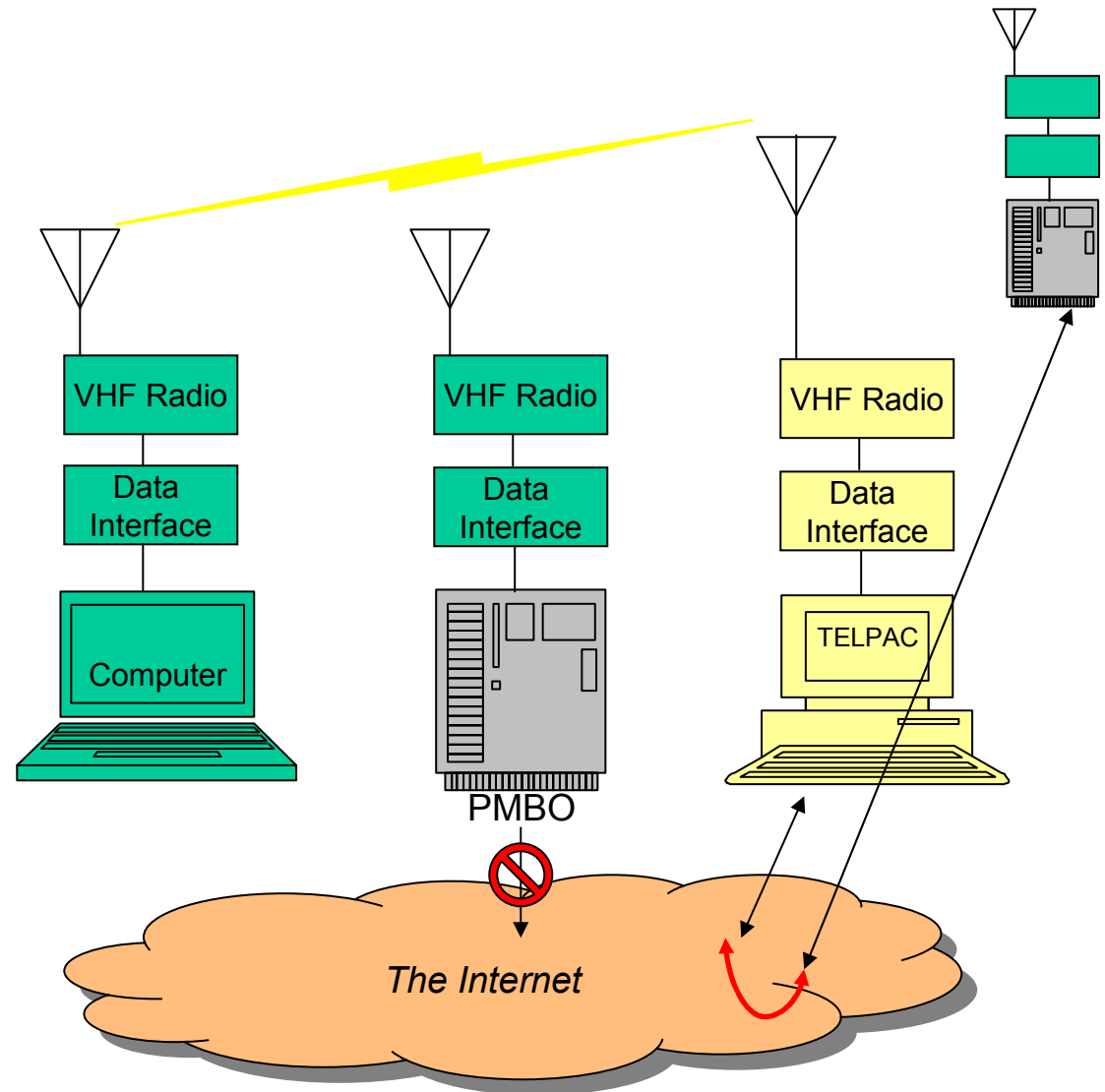
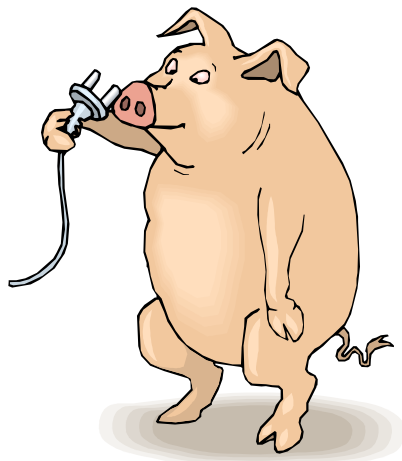

E-MAIL VIA HAM RADIO

Or... you can traverse the **packet network** using nodes to get to a connected **TELPAC** or **PMBO**. Or...

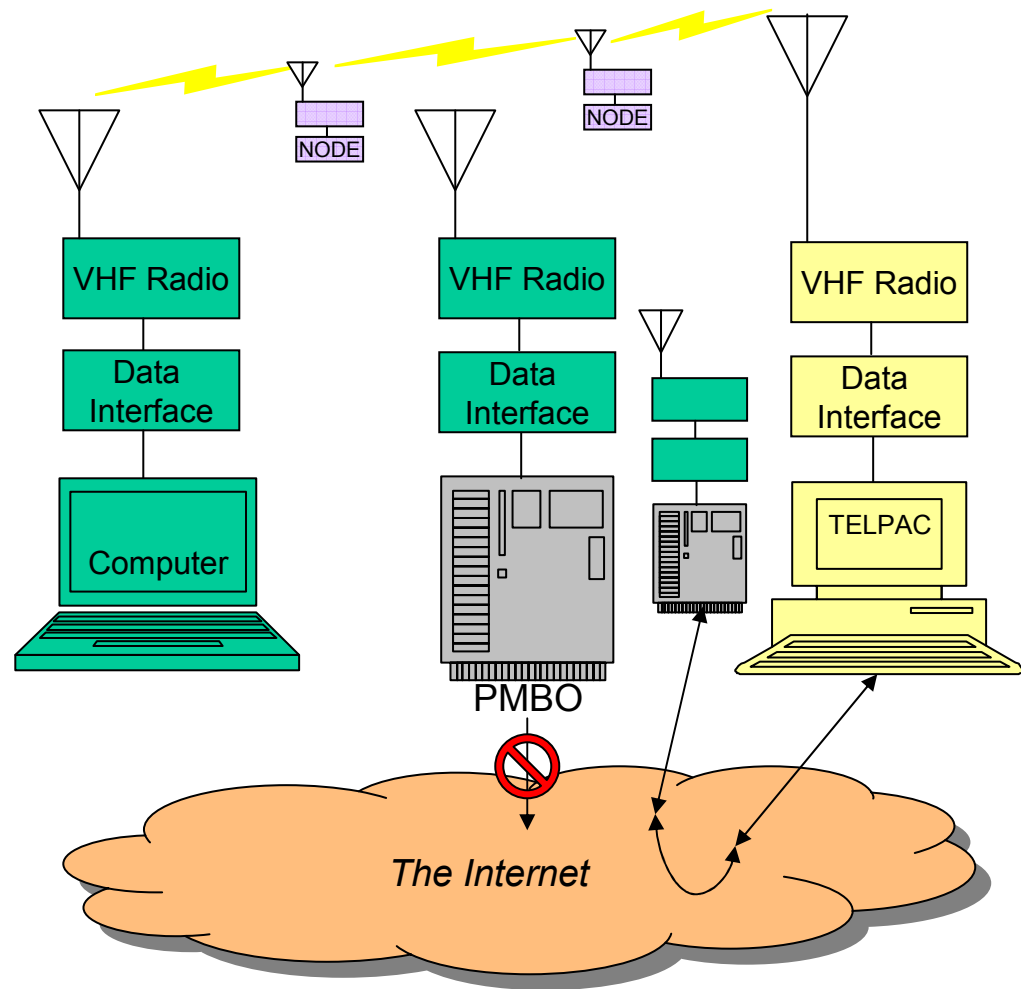
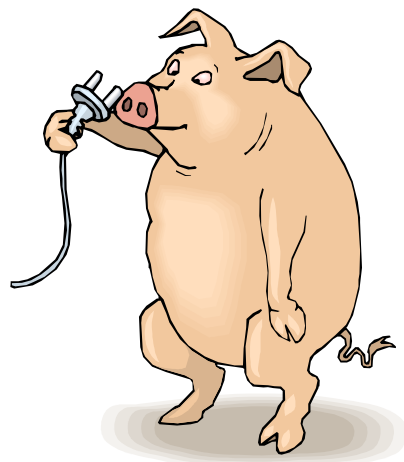

E-MAIL VIA HAM RADIO

Or... you can use an **HF station** to get to a distant connected **PMBO** using **Airmail**.

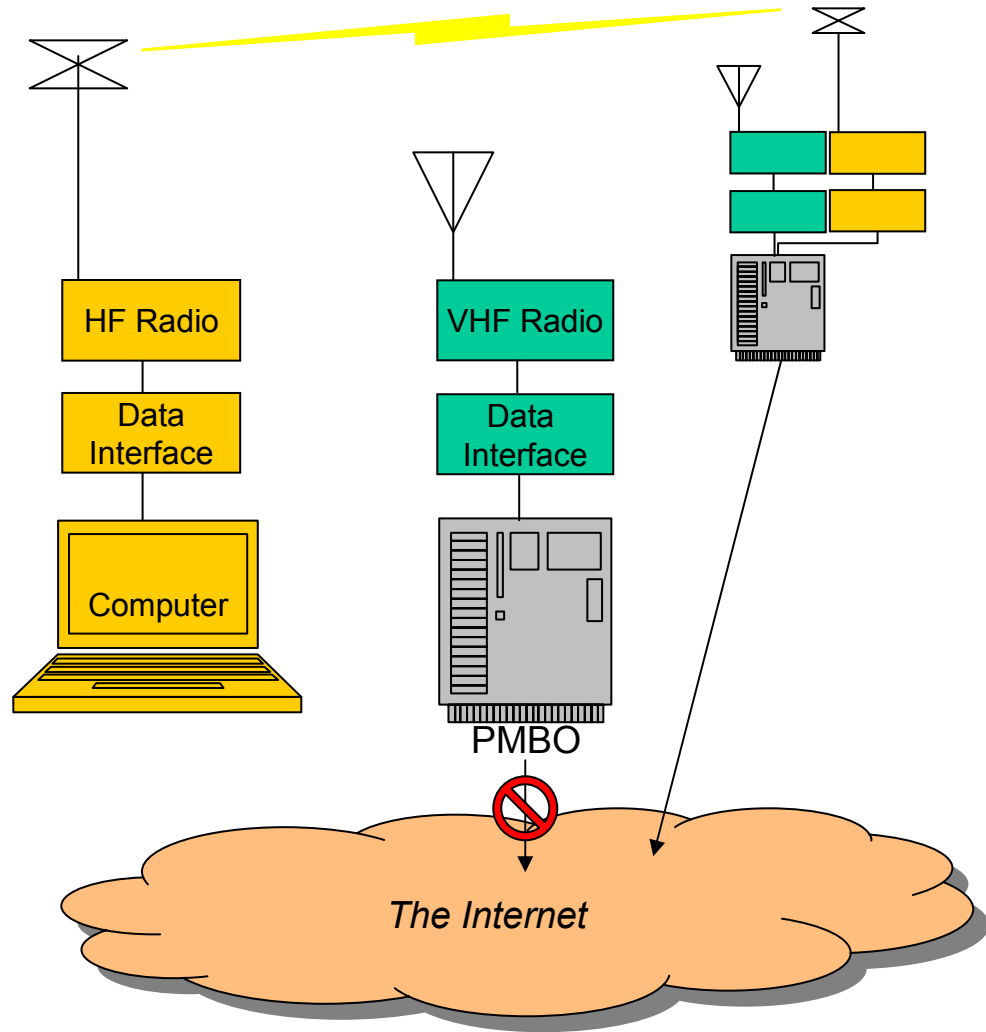
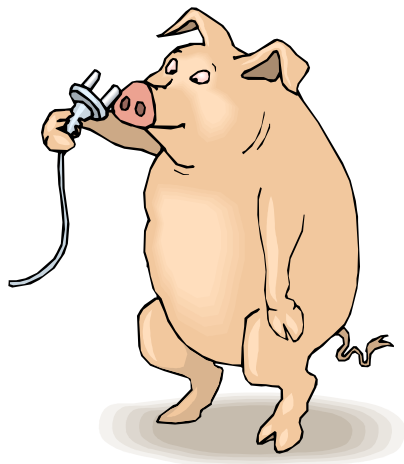

E-MAIL VIA HAM RADIO

Besides radio channels, **PACLINK** stations also may have **telnet** channels to the internet. This is handy for fixed stations because it is fast.

PACLINK stations automatically switch between preset radio destinations and **telnet** channels to find a connection to a **PMBO**.

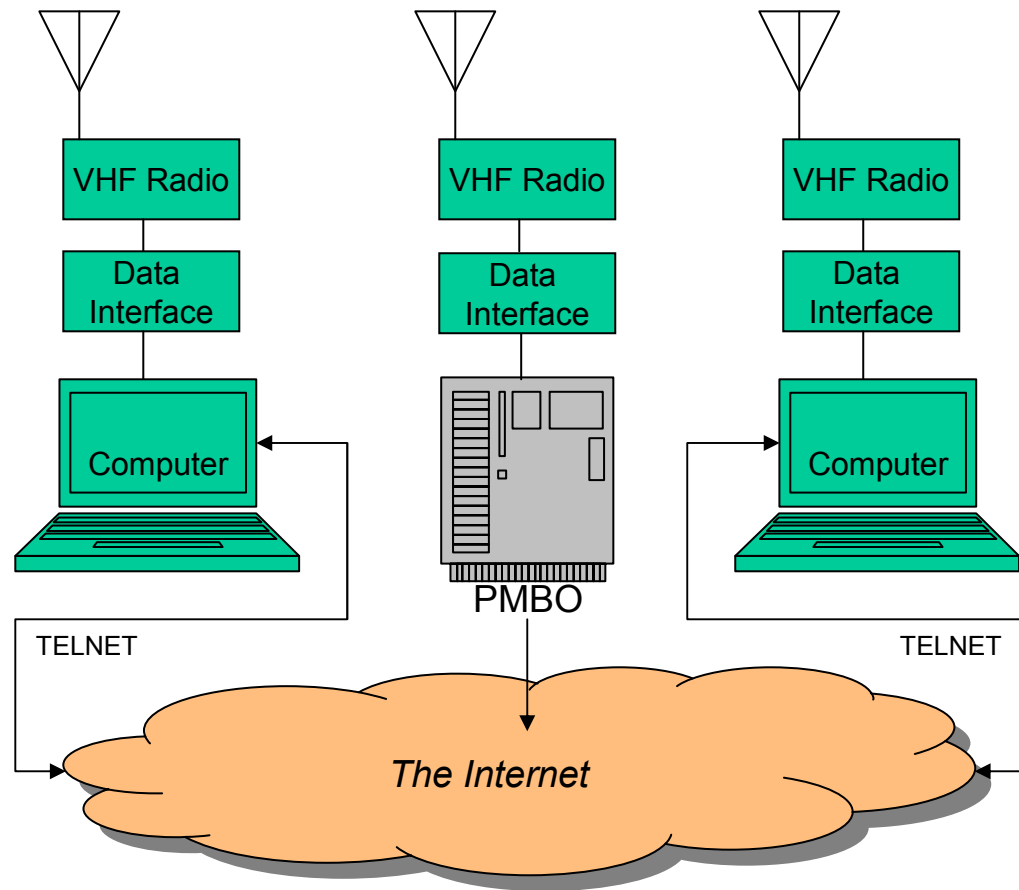
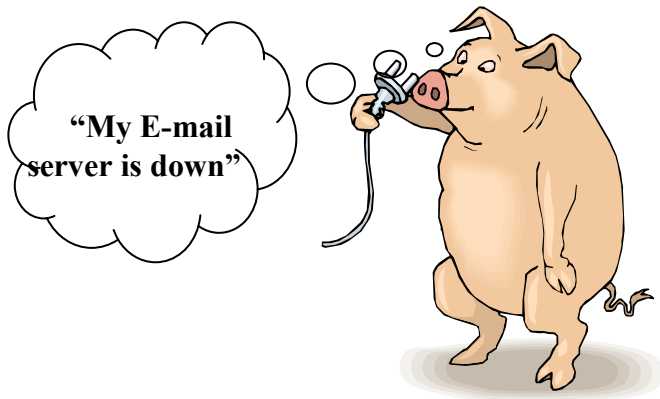

So, what does all this
look like?

“Real life” examples

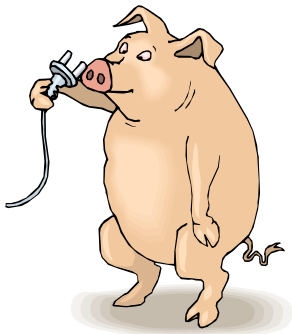

E-MAIL VIA HAM RADIO

Harris County (Houston,) Texas. “A mature system.”



Williamson County, TN, “A works in process.”

The Williamson County, TN, WCARES Winlink 2000 network revolves around several ‘hardened’ sites in prime locations. Multiple PMBO and TELPAC gateway sites add redundancy.

- Telpac Gateway sites use 802.11b to back to the EOC.
- First Telpac Route for all sites is Telnet (Internet.)
- Second Telpac route is telnet to the K4CJX PMBO
- Outbound EOC PMBO D-Star route to external Internet gateway.

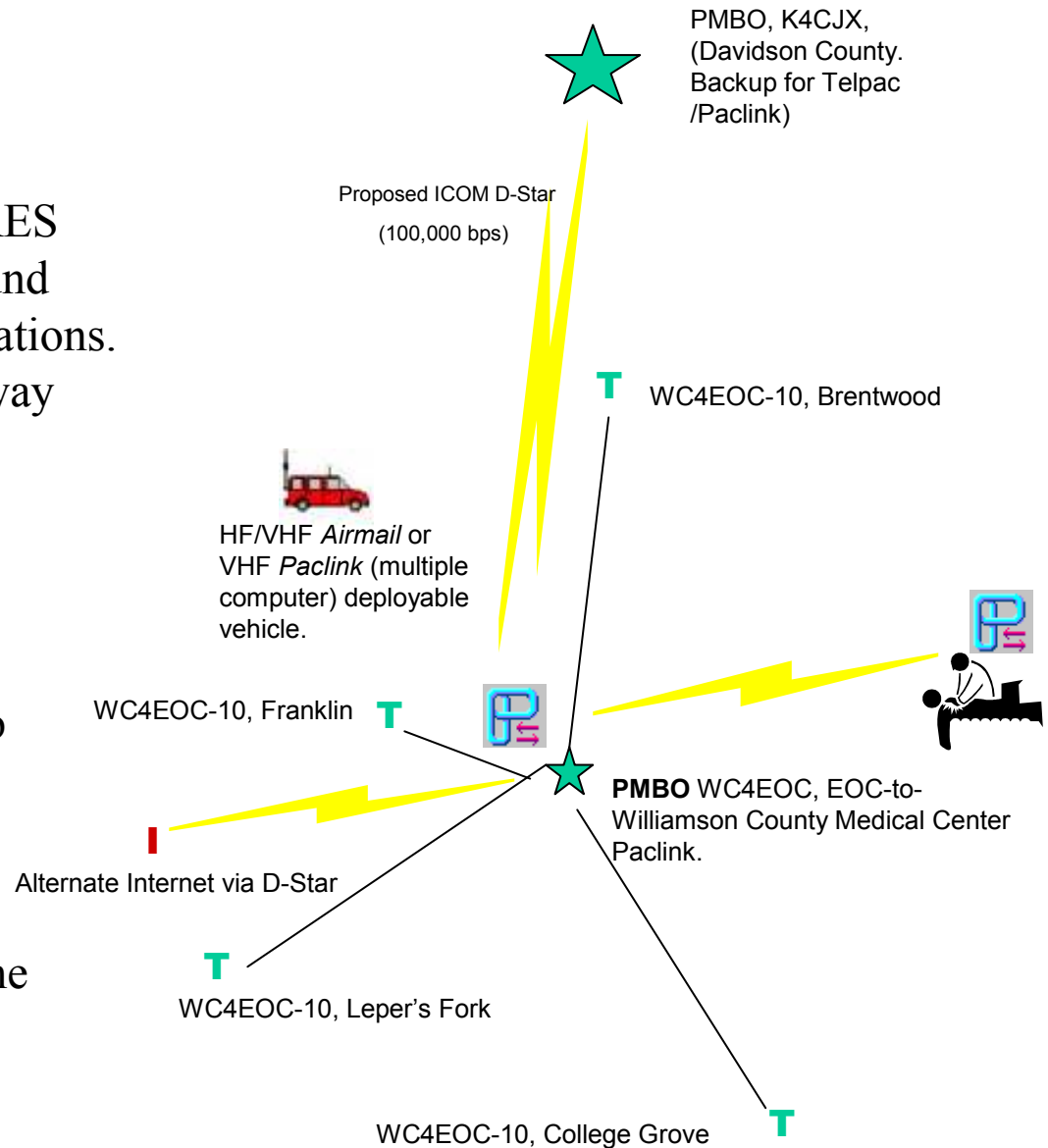

So, What's Next?

- *Examine the option: what else is available* for complex radio messaging? Does it provide end-to-end, transparent, multiple recipient de facto e-mail to the community Served Agencies desktops?
- Make a “yes/no” decision about **Winlink 2000**. If “yes,” then...
 - Learn to use **Airmail**, **Telpac** and **Paclink**.
 - Deploy local **Telpac** gateway(s).
 - Deploy mobile **Paclink** & fixed Paclink LANs in places where it will be of value during an emergency.
 - Deploy VHF/UHF new or existing links to bring it all together.
 - Deploy self-powered, mobile/fixed **Airmail**, long-range HF Stations.
 - Consider a non-public “hubbing” PMBO for the area
- **Meanwhile.....**

Devise a Plan!

- Insure that there is ***no duplication of efforts*** in your “last mile” coverage area.
- Set up an strategy for implementation with your local ARRL ARES® or RACES organization. Set up a time-line for each task.
 - Coordinate efforts with the Winlink 2000 Development Team, EC’s, SECs, DEC’s/SM, etc.
 - Ask other ARES® communities for assistance.
 - **Set up personnel responsibilities with Time-lines!**
 - **Handle the finances.** “How much will it actually cost”? Who should pay?
 - **Involve and commit the end-user. They are the one’s to benefit!**
- Implement the plan in stages.
- Test it, and Test it again.
- Provide a presentation and demo for your served agencies.
- Continue to promote your capabilities.

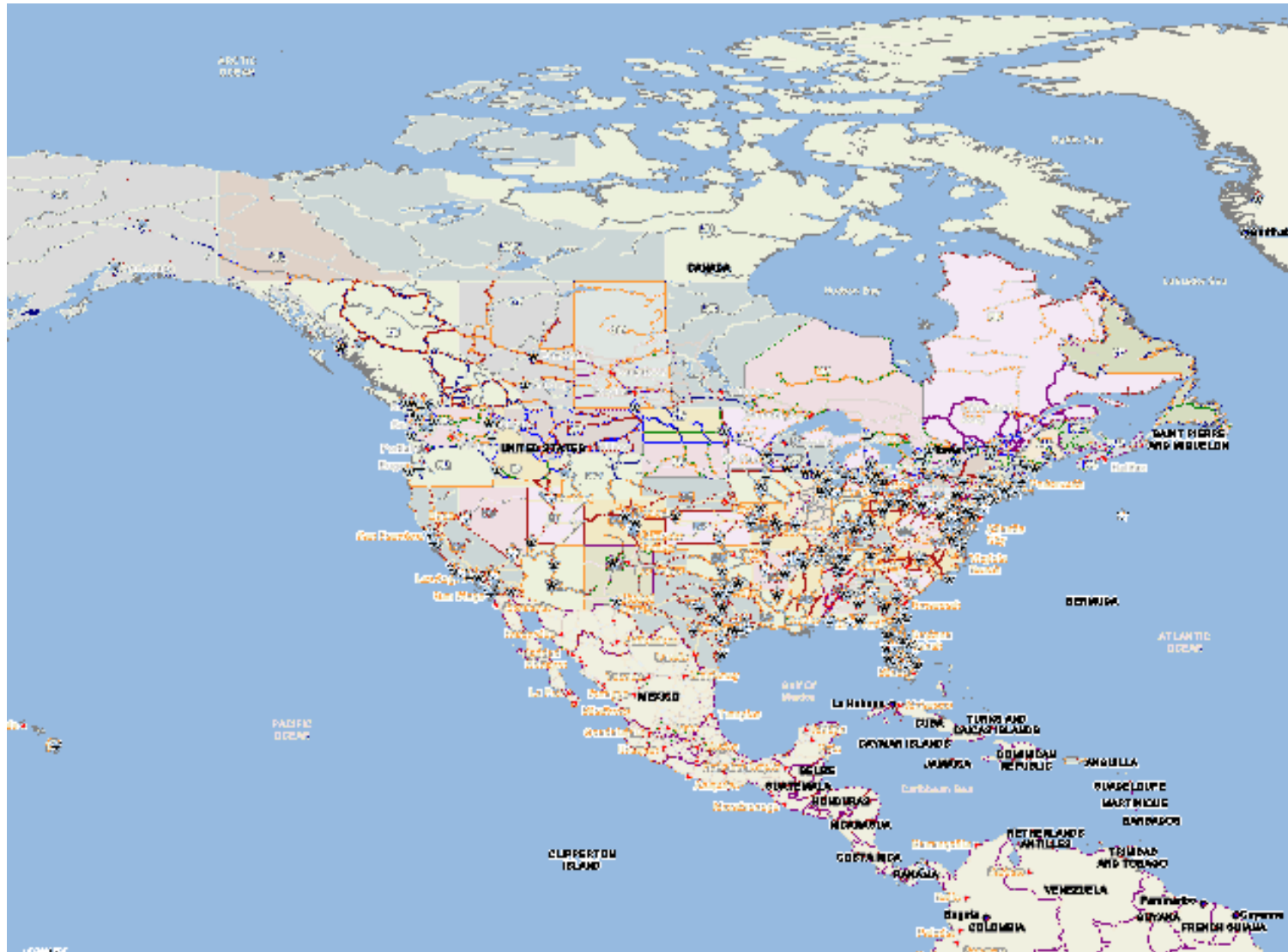

Winlink 2000 is a proven, existing, operational, dependable, redundant, secure, reliable Amateur radio e-mail messaging network that is being made available to the ARES® & RACES communities.

(However, each community must put it in place.)



Any Questions?